



**NTM Classification Meeting**  
**Official Non-Tariff Measures**  
**28 – 29 September 2015**

**Ralf Peters,**  
**Division on International Trade in Goods and Services,**  
**and Commodities**  
**UNCTAD**



---

# UNCTAD Non-Tariff Measures Programme

- Working along the entire chain

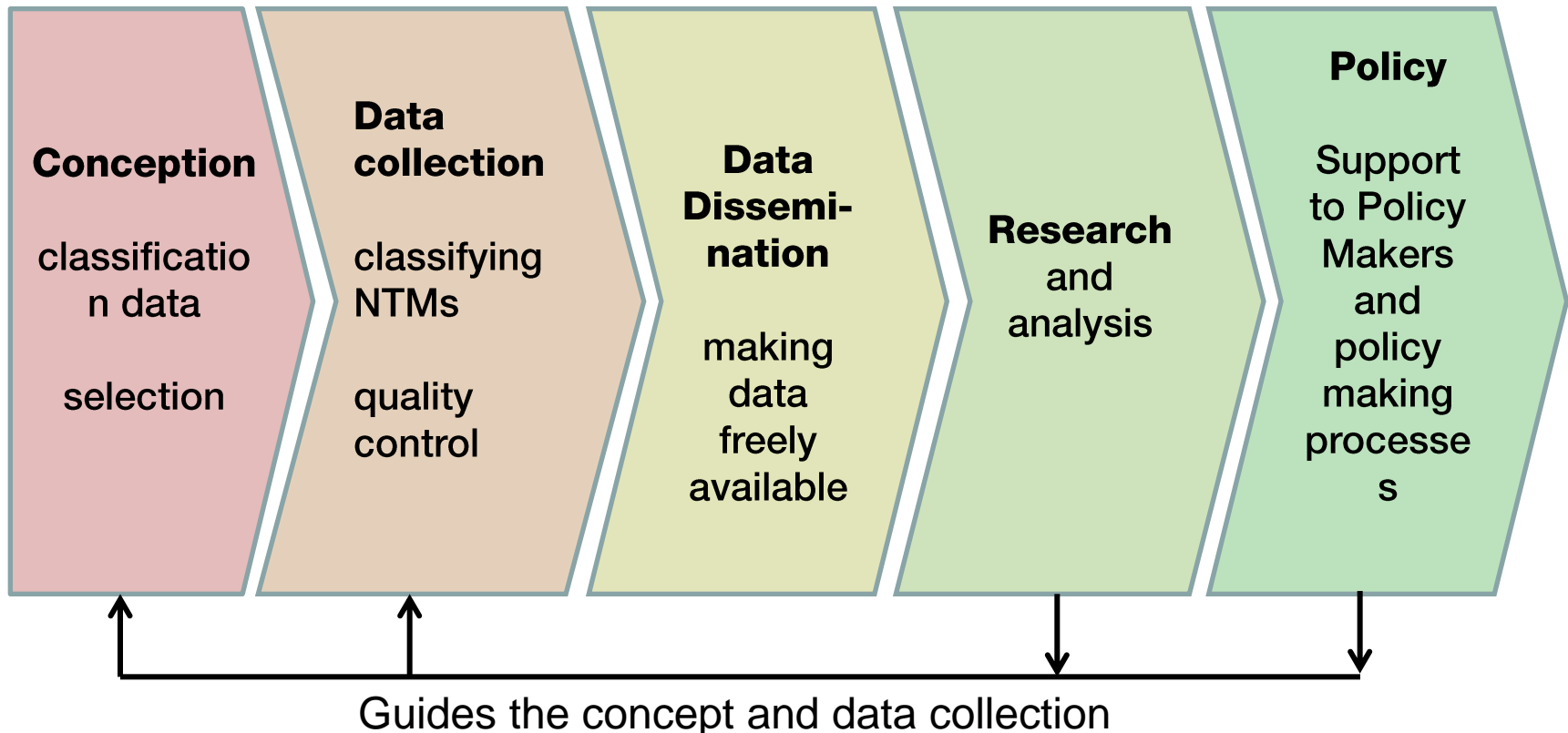

# NTM Data: 3 Types of data, not to be mixed

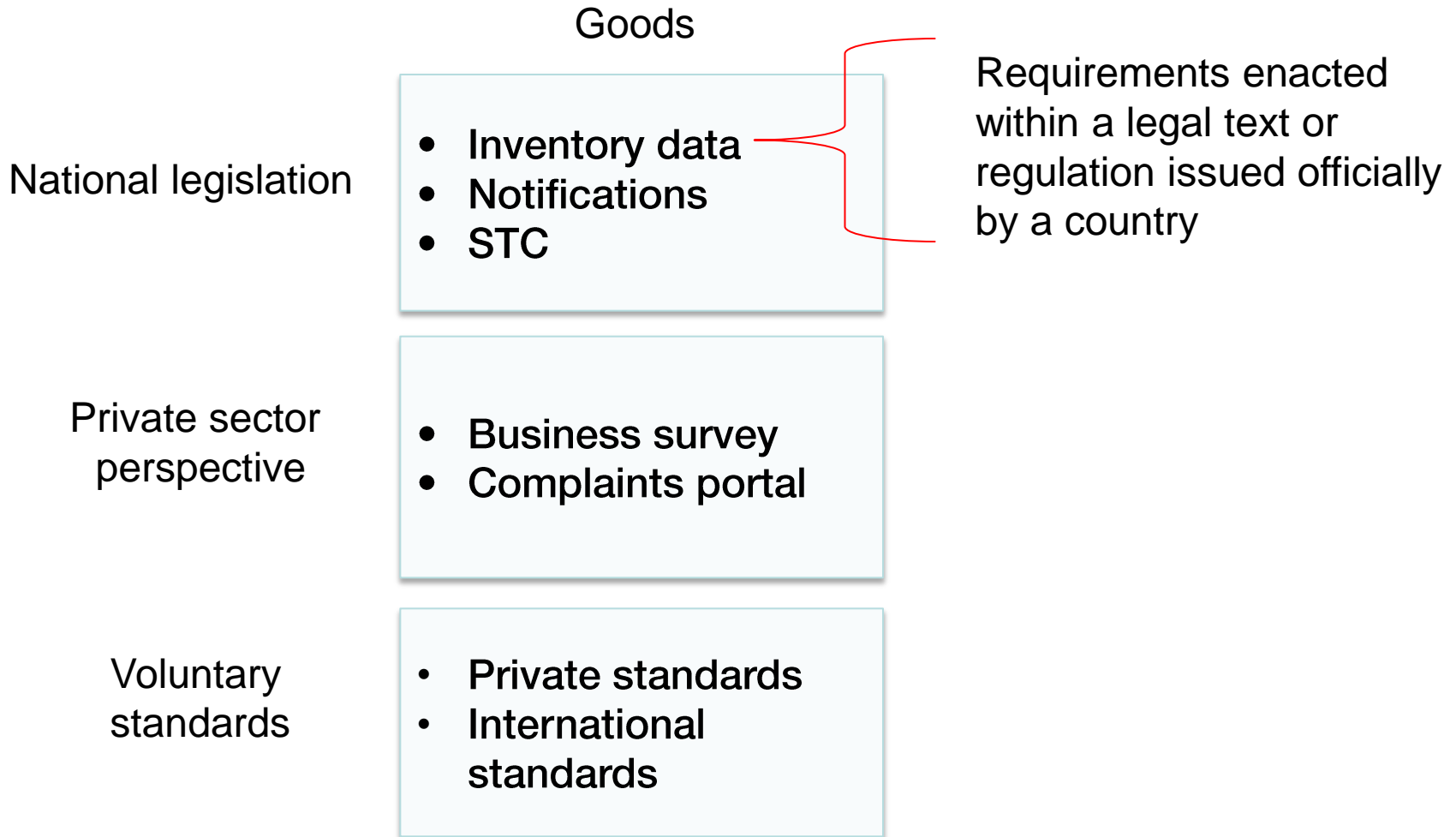

# International Classification of NTMs: The common language

<b>Import-related measures</b>	<b>Technical measures</b>	A	Sanitary and Phytosanitary (SPS) measures	<p><b>Tree structure -- for example:</b></p> <p>A Sanitary and Phytosanitary (SPS) measures</p> <p>A1 Prohibitions/restrictions of imports for SPS reasons A11 Temporary geographic prohibition (...)</p> <p>A2 Tolerance limits for residues and restricted use of substances (...)</p> <p>A3 Labelling, marking, packaging requirements (...)</p> <p>A4 Hygienic requirements (...)</p> <p>A5 Treatment for the elimination of pests and diseases A51 Cold/heat treatment A52 Irradiation (...)</p> <p>A6 Requirements on production / post-production processes (...)</p> <p>A8 Conformity assessment A81 Product registration A82 Testing requirement A83 Certification requirement A84 Inspection requirement A85 Traceability requirement A851 Origin of materials and parts A852 Processing history (...)</p> <p>A86 Quarantine requirement A89 Other conformity assessments</p>
		B	Technical barriers to trade (TBT)	
		C	Pre-shipment inspections and other formalities	
	<b>Non-technical measures</b>	D	Contingent trade-protective measures	
		E	Non-automatic licensing, quotas, prohibitions and quantity-control measures	
		F	Price-control measures, including additional taxes and charges	
		G	Finance measures	
		H	Measures affecting competition	
		I	Trade-related investment measures	
		J	Distribution restrictions	
		K	Restrictions on post-sales services	
		L	Subsidies (excl. export subsidies)	
		M	Government procurement restrictions	
		N	Intellectual property	
		O	Rules of origin	
<b>Export-related measures</b>	P	Export-related measures		

UNITED NATIONS CONFERENCE ON TRADE AND DEVELOPMENT  
**UNCTAD**

**CLASSIFICATION OF NON-TARIFF MEASURES**  
FEBRUARY 2012 VERSION

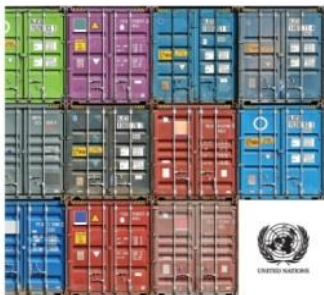

# Official NTM data collection

● From here...

...to here

## The Gazette of the Democratic Socialist Republic of Sri Lanka EXTRAORDINARY

අංක 1376/9 - 2005 ජනවාරි 19 වැනි බදාදා - 2005.01.19  
No. 1376/9 - WEDNESDAY, JANUARY 19, 2005

(Published by Authority)

### PART I : SECTION (I) — GENERAL Government Notifications

L.D. - B. 11/80 II

#### FOOD ACT, No. 26 OF 1980

REGULATIONS made by the Minister of Health in consultation with the Food Advisory Committee under No. 26 of 1980.

Colombo.  
17th January, 2005.

#### Regulations

01. These Regulations may be cited as "Food (Labelling and Advertising) Regulations 2005."

02. No person shall sell, offer for sale, expose or keep for sale, transport or advertise for sale, any food in a container unless such package or container is labelled in accordance with these regulations.

Provided however that, these regulations shall not apply to any package of food if the food is of the name or brand requested by the purchaser and is weighed, counted or measured in the presence of the purchaser.

NIMAL SIR  
Minister of Health  
Uva Weillas

Document Title	Regulation Title Short	NTM Code	Measure Implementation Date	Measure Repealed Date	Measure Description	Affected Products Description	Affected Countries
Food Act	Food (Control of import, labelling, and sale of genetically modified foods) Regulation 2006	B14	01/01/2007		Needs to get approval of the Chief Food Authority in order to import	Food products	All countries
Food Act	Food (Control of import, labelling, and sale of genetically modified foods) Regulation 2006	B31	01/01/2007		Labelling Requirements	Food products	All countries
Food Act	Food (Irradiation) Regulations 2005	A31	01/05/2006		Labelling Requirements	Food products that had been treated with irradiation	All countries
Food Act	Food (Irradiation) Regulations 2005	A83	01/05/2006		Certification by the competent authorities of the country of origin that the food has been inspected	Food products that had been treated with irradiation	All countries
Food Act	Food (Irradiation) Regulations 2005	A89	01/05/2006		Documentation that the Food Irradiation Facility concerned is approved, licensed, authorised by the competent national authority of food irradiation	Food products that had been treated with irradiation	All countries
Food Act	Food (Irradiation) Regulations 2005	P62	01/05/2006		Certification by the competent authorities of the country of origin that the food has been inspected	Food products that had been treated with irradiation	All countries
Food Act	Food (Melamine in Milk and Milk Products) Regulations 2010	A22	01/01/2011		Specifying permitted ppm levels of melamine in milk and milk products	Milk and Milk Products	All countries
Food Act	Food (Melamine in Milk and Milk Products) Regulations 2010	A83	01/01/2011		A health certificate required from the National Food Safety Authority of the country of origin that the products conform to the levels of melamine specified	Milk and Milk Products	All countries
Food Act	Food (Packaging materials and articles) Regulation 2010	A32	01/06/2011		Marking requirements - need to print the words "FOR FOOD USE" or any other relevant words or symbols as indicated in the regulation	Food packaging material	All countries
Food Act	Food (Packaging materials and articles) Regulation 2010	A83	01/06/2011		Certification by the manufacturer that the material meets required quality standards	Food packaging material	All countries
Food Act	Food (Packaging materials and articles) Regulation 2010	A22	01/06/2011		Restricted use of certain substances in food packaging material	Food packaging material	All countries
Food Act	Food (Preservatives) Regulations	A19	01/01/1991		Prohibited to import, manufacture, sell or distribute food preservatives other than those specified in the regulation & food which has in or upon it any preservative that is permitted by the regulation	Food preservatives	All countries

# How is the data collected?

Regulation ➔ Law, decree, etc. issued officially by a government

Measure ➔ One official regulation could bear several NTM

Currently chapters A – I and P

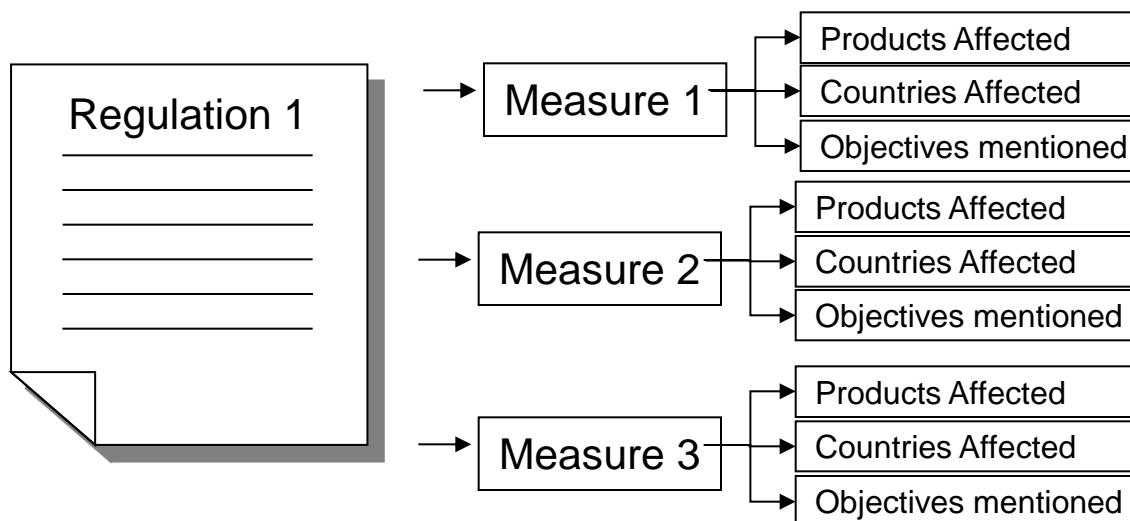

# Data Availability

Latin America and the Caribbean	North America	Europe and Central Asia	Middle East and North Africa	Sub-Saharan Africa	South Asia	East-Asia and the Pacific
Argentina	US	E.U.	Egypt	Burkina Faso	Afghanistan	China
Bolivia	Canada	Kazakhstan	Lebanon	Cote d'Ivoire	India	Japan
Brazil		Russia	Morocco	Guinea	Nepal	Hong Kong, C
Chile		Tajikistan	Tunisia	Madagascar	Pakistan	Australia
Colombia		Belarus	Algeria	Mauritius	Sri Lanka	New Zealand
Costa Rica			Jordan	Namibia		All ASEAN
Cuba			Palestine	Senegal		Korea
Ecuador				Tanzania		
Guatemala				Kenya		
Mexico				Malawi		
Paraguay				Rwanda		
Peru				Nigeria		
Uruguay				Benin		
Venezuela				Cape Verde	Liberia	
El Salvador				Gambia	Mali	
Honduras				Ghana	All TRIPARTITE	
Nicaragua				Guinea Bissau		

# Map of Data Availability

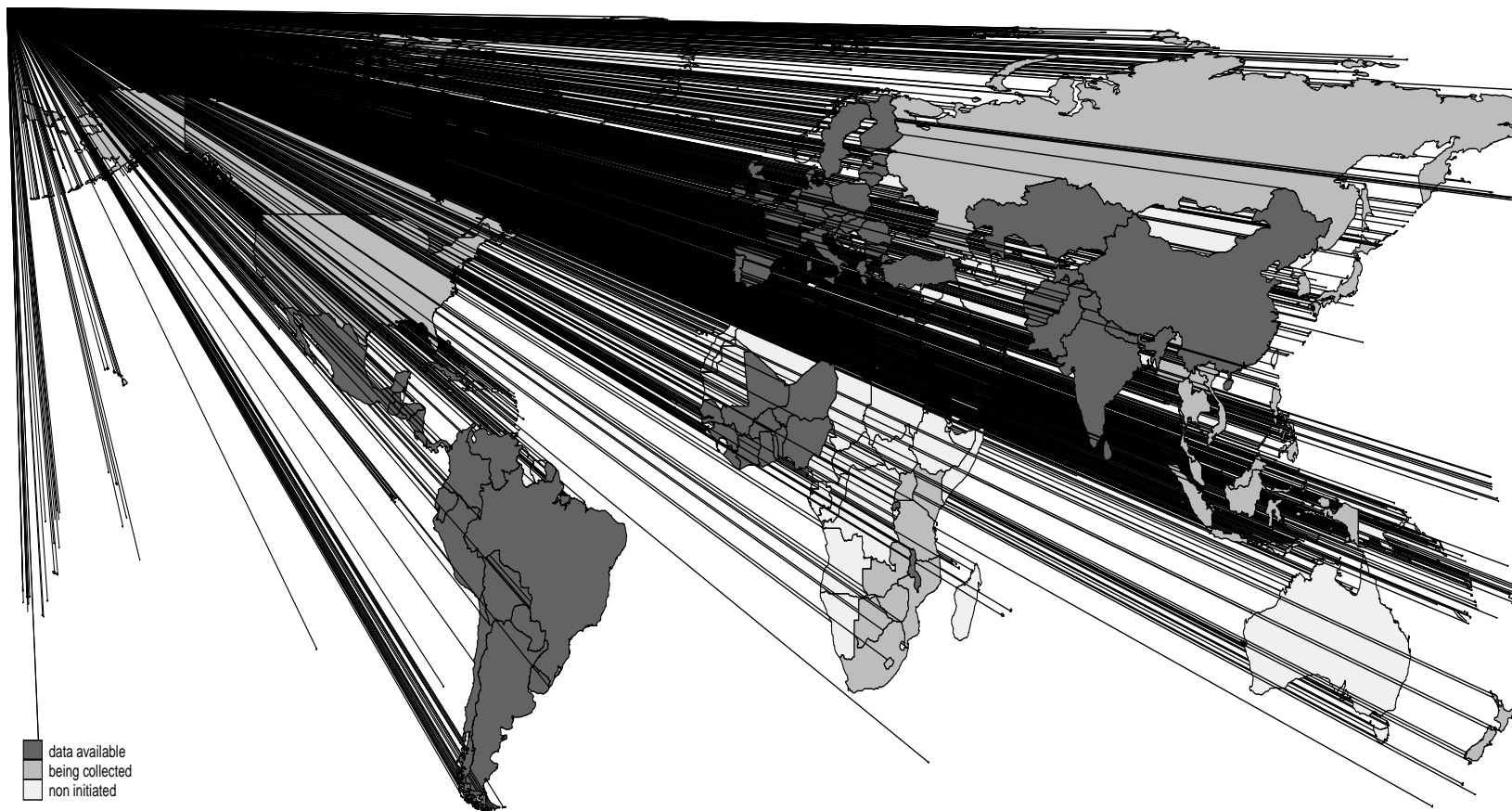



# World Integrated Trade Solution website: wits.worldbank.org

The screenshot displays the WITS website interface. At the top, there is a navigation bar with links for Home, About WITS, Country Profile, Reference, Training, GPTAD, and Support Links. The main content area is divided into several sections:

- INTRODUCTION:** A text block explaining the WITS software's capabilities in providing access to international merchandise trade, tariff, and non-tariff measures (NTM) data.
- MY COUNTRY:** A dropdown menu set to Switzerland for the year 2012, with a link to view detailed data.
- Trade Summary:** A table showing key trade indicators for Switzerland:
 

Import (US\$ Mil)	197,787
Export (US\$ Mil)	225,949
Weighted Average Tariff (%)	...
Trade (% of GDP)	94.16
GDP (current US\$ Mil)	631,000
- Export Partners:** A bar chart showing the top export partners for Switzerland, including Germany, United States, Italy, France, and United Kingdom.
- Exports by Product Groups:** A bar chart showing the composition of exports into Consumer goods, Intermediate goods, Capital goods, and Raw materials.
- WITS CUSTOM QUERY:** A section for users to execute custom queries, with a 'Register Now' button and a 'Login' link for existing members.
- WORLD AT A GLANCE:** Two tables showing top importers and top exporters for 2012.
 

Country	Trade (US\$ Mil)	Share %
United States	2,028,202	11.83
China	1,391,648	8.12
Germany	1,061,773	6.19
Japan	664,999	3.88
United Kingdom	644,221	3.76

Country	Trade (US\$ Mil)	Share %
China	2,280,298	12.90
United States	1,438,335	8.21
Germany	1,298,071	7.41
Japan	867,318	4.95
France	550,992	3.15
- Exports by Product Groups 2012:** A bar chart showing the composition of exports for 2012, similar to the main 'Exports by Product Groups' chart.
- SUPPORT LINKS:** A list of links including Glossary, Metadata, Concordances, Did you know, and FAQ.
- TOOLS:** Links to a Simulation Tool and an Offline Tool.
- FEATURED:** A section highlighting featured content, including a bar chart showing 80% for two categories.
- RELATED LINKS:** A list of external links related to trade, including Transparency in Trade, UNCTAD TRAINS, and World Bank Trade Post.

# Example: Many distinct SPS measures on fish products

Average number of distinct SPS and TBT measures by country

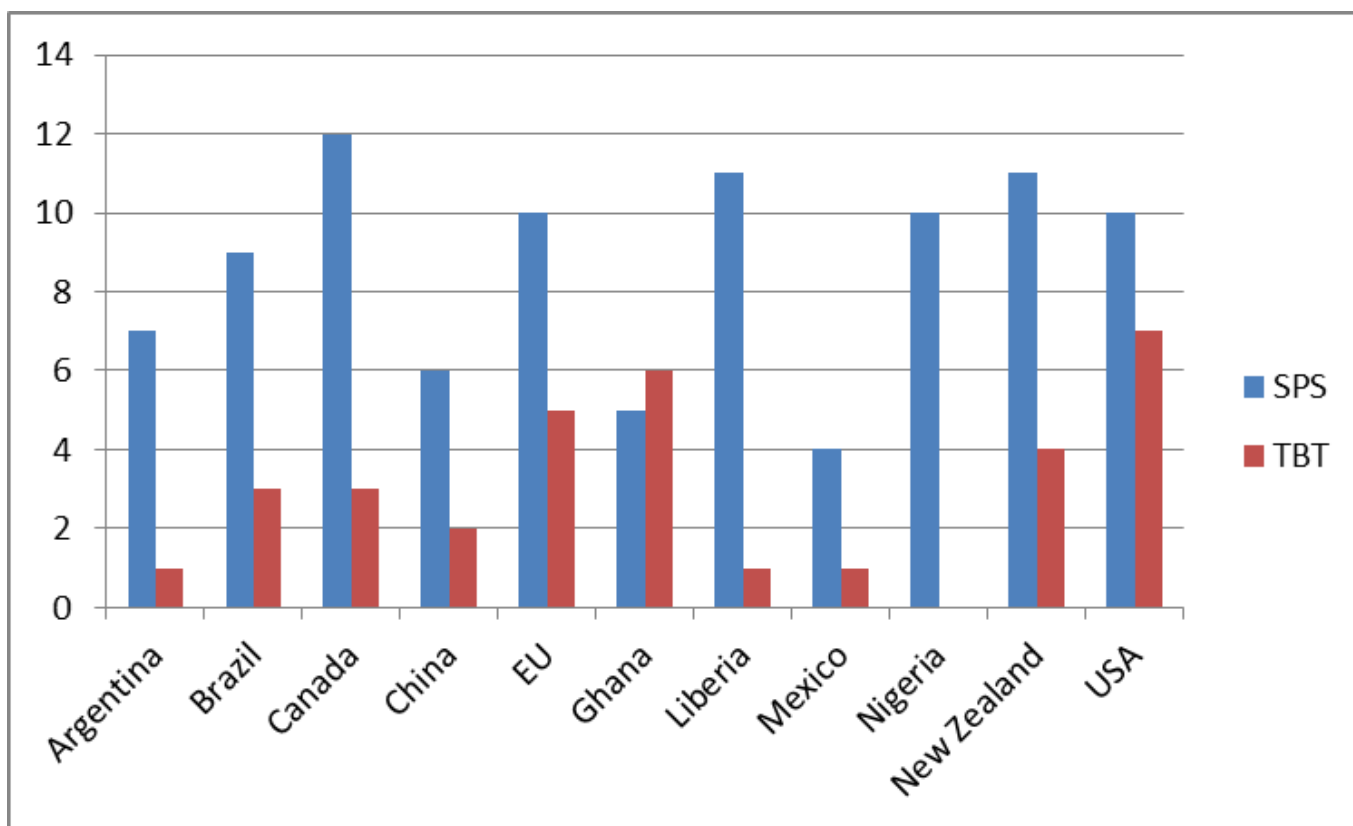

# Main Challenges with NTM data collection

## Comprehensiveness

Regulations

Measures  
within Regulations

## Quality

NTM classification

HS classification



# Towards high quality data

## Before

- Selection, Training, Preparation (e.g. sources, “legal architecture”)

## During

- **Being constantly with the classifier**

## After

- Automated data review
  - Data consistent (e.g. all mandatory fields filled in)
  - Anti-dumping measure for one product
- Semi-automated review (supporting manual review, e.g. flagging issues)
  - SPS measures mainly for food products
  - Flag partial coverage with large product groups
- Manuel data review
  - Sources
  - NTM classification
  - Product classification



## Still ... challenges remain

- Labour intensive and time consuming
- Sometimes difficulties to classify, e.g. SPS vs TBT
  - Often difficult judgement to make
  - Internal “committee”
- HS classification is a huge effort (1/3 of time)
  - Often groups of products
  - Often for specific use
- Difficult but doable



# UNCTAD

PROSPERITY FOR ALL

[www.unctad.org](http://www.unctad.org)  
[unctad.org/ntm](http://unctad.org/ntm)



UNITED NATIONS  
UNCTAD